

GENERAL INFORMATION

Project Name: _____
Item: _____
Quantity: _____
Model: ZG9500-2
Length: _____

STANDARD NSF LISTED FINISH OPTIONS

- | | |
|---|--|
| <input type="checkbox"/> Brushed Aluminum | <input type="checkbox"/> Chrome |
| <input type="checkbox"/> Gloss Black | <input type="checkbox"/> Wrinkle Black |
| <input type="checkbox"/> Smoked Copper | <input type="checkbox"/> Polished Brass Finish |
| <input type="checkbox"/> Other _____ | |

GLASS THICKNESS

- | |
|--|
| <input type="checkbox"/> 1/4" Tempered Glass (not for shelves)
Centerline Max 54" |
| <input type="checkbox"/> 3/8" Tempered Glass (for shelf or span more than 54")
Centerline Max 66" |

GLASS CORNERS

- | | |
|--|---|
| <input type="checkbox"/> 1" Radius Corner (standard) | <input type="checkbox"/> Square Corners |
|--|---|

INSTALLATION OPTIONS

Above-Counter: Stainless Steel Counter
Under-Counter: Stainless Steel Counter
 (Requires Under-Counter Reinforcement & Access)

Above-Counter: Millwork Counter

Under-Counter: Millwork Counter

See Installation Page for More Details.

ZG9500-2 Self-Serve w/Top Shelf or Two-Tier Display Shelf

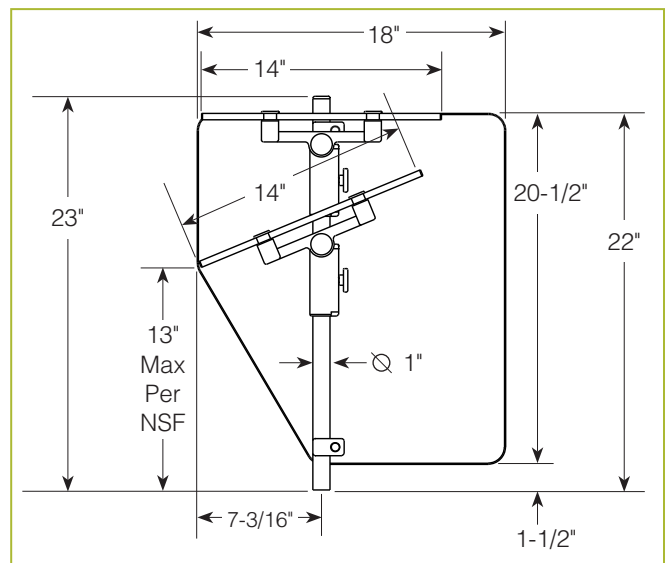

To meet NSF guidelines, end panels are included on all BSI quotations unless specifically excluded. (See End Panel Page for More Details.)

- | |
|--|
| <input type="checkbox"/> SS1: EZ Mount 2" x 8" Flange |
| <input type="checkbox"/> SSU3-H: Heavy-Duty Flange |
| <input type="checkbox"/> SSU3-N: Narrow Flange |
| <input type="checkbox"/> SSU5-H: Heavy-Duty Flange |
| <input type="checkbox"/> SSU5-N: Narrow Flange |
| <input type="checkbox"/> MW1: Heavy-Duty Flange |
| <input type="checkbox"/> MW2: Narrow Flange |
| <input type="checkbox"/> MWU3: Narrow Flange |
| <input type="checkbox"/> MWU4: Compression Installation (not recommended for solid surfaces) |
| <input type="checkbox"/> MWU5: Heavy-Duty Flange |

* Approval Drawings Required